

VICOR CONFIDENTIAL

THIS DOCUMENT AND THE DATA DISCLOSED HEREIN OR HEREWITH IS NOT TO BE REPRODUCED, USED OR DISCLOSED IN WHOLE OR IN PART TO ANYONE WITHOUT THE PERMISSION OF VICOR CORP.

REVISIONS				
REV	DESCRIPTION		DATE	APPROVED
1	RELEASE PER E9830074	PEI	11/13/98	JMR
2	REVISED PER E0030403	PEI	12/15/00	JMR
3	REVISED PER E100944	KUK	07/22/10	DCS

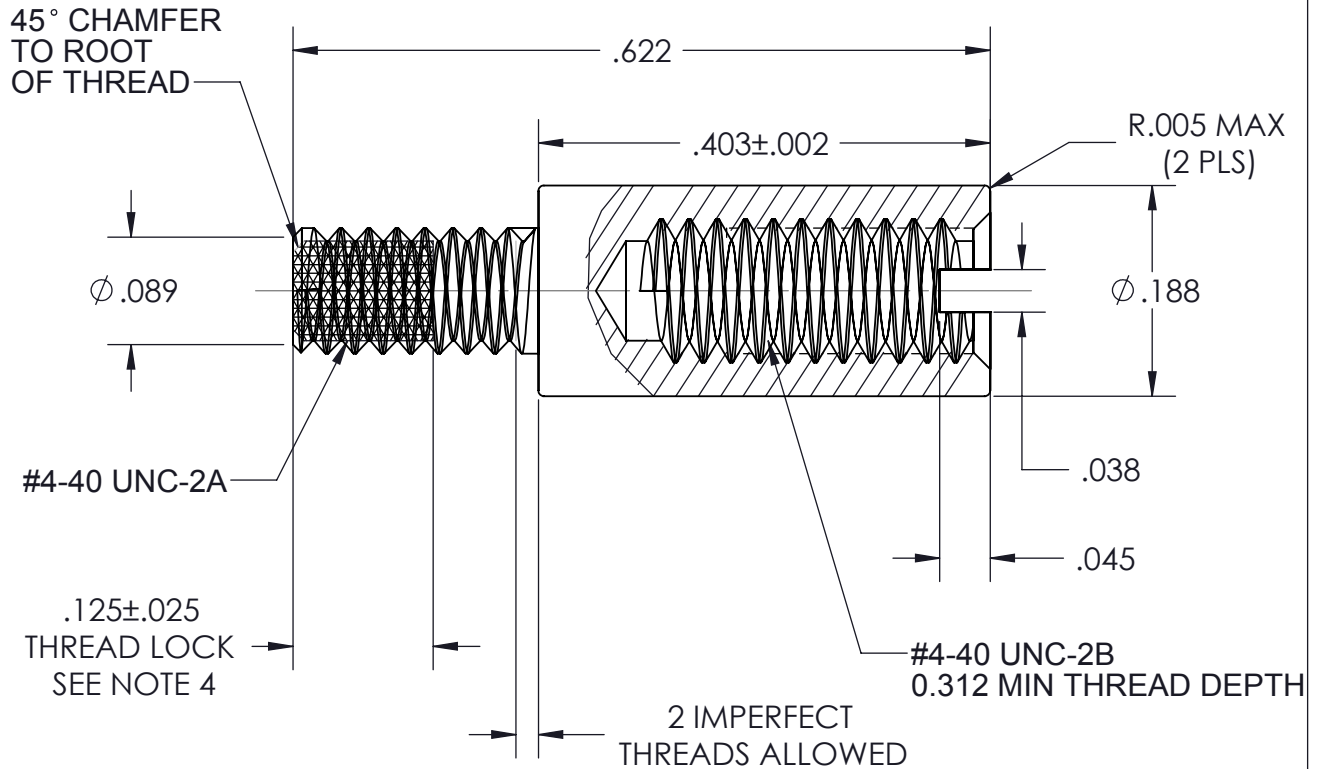

NOTES:

1. MATERIAL: 300 SERIES STAINLESS STEEL PER AISI.
2. FINISH: CLEAR PASSIVATE PER QQ-P-35B, TYPE II.
3. REMOVE ALL BURRS AND SHARP EDGES.
4. MACHINE APPLY LOCTITE DRI-LOC 204 OR EQUIVALENT TO THREADS AS SHOWN.
5. KIT P/N 18157
6. BAG P/N 19133
7. DIMENSIONS ARE INCHES ONLY.

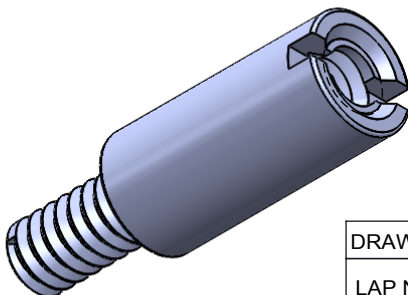

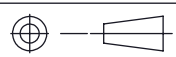
DRAWN	DATE	 VICOR		SWD	
LAP NGUYEN	11/24/97	STANDOFF, 0.403 LG MALE-FEMALE			
MATERIAL	UNLESS OTHERWISE SPECIFIED DIMENSIONS ARE INCH [MM] TOLERANCES ARE: DECIMALS ANGLES X.XX [X.X] = ±0.01 [0.25] ±1° X.XXX [X.XX] = ±0.005 [0.127]	SIZE	CAGE CODE	DWG NO	REV
FINISH	THIRD ANGLE PROJECTION 	A	67131	18121	3
DO NOT SCALE DRAWING		SCALE 6 : 1		SHEET 1 OF 1	